

# Joint Ball 16 November 2024

## 1 ST ANDREW'S FAIR J32 · 3/4L

Roy Goldring: *Five Scottish Country Dances 1982* · Crib: *E-cribs* · Diagram: *Keith Rose's Diagrams*

- 1- 1c cross RH | cast off 2 (2c up) ; cross LH and cast up (2,1,3)
- 9- All turn RH ½ | retain hold & set ; all chase clw to own sides (3,1,2)
- 17- 3c+1c+2c Circle6 and back
- 25- All turn LH ½ | retain hold & set ; all chase cclw to (2,1,3)

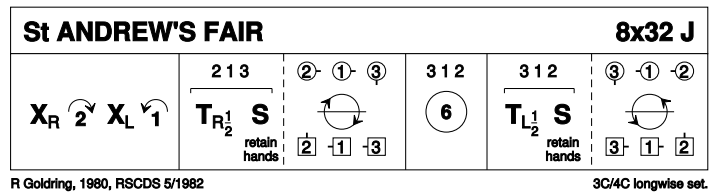

Note: 3c does not move on bars 1-8.

## 2 RED HOUSE R40 · 2/4L

Playford: *RSCDS VII 2* · Crib: *E-cribs* · Diagram: *Keith Rose's Diagrams*

- 1- 1c set and cast off one ; set and cast back
- 9- 1M cast off (1W follows) behind 2M, between 2c, behind 2W and cross to finish below 2M/2W
- 17- 1W cast up (1M follows) behind 2W, between 2c, behind 2M and cross to finish 1c in own places
- 25- 1c+2M Reel3 on M sideline (1M & 2M begin Lsh, 1W entering below them ; 1M+2M end in exchanged places, 1W in own place
- 33- 1c+2W Reel3 on W sideline (1W & 2W begin Rsh, 1M entering below them, finish (2,1)

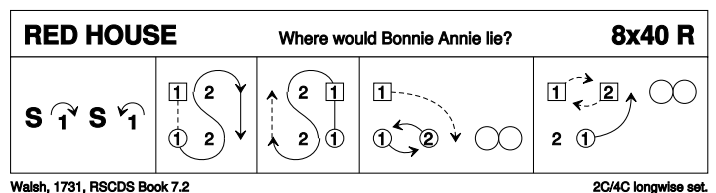

## 3 GANG THE SAME GATE S32 · 3/4L

Milton Levy: *RSCDS XXXVI 4* · Crib: *E-cribs* · Diagram: *Keith Rose's Diagrams*

- 1- 1c cross RH | cast off 2 (2c+3c up) ; 1c cross RH and cast up (3c down) to (2,1,3)
- 9- 1c set passing Lsh | turn 1cnrs BH ; ½Reel4 with 2cnrs, at end 1c curve R to between end cpl (M above facing W below)
- 17- 1c set passing Lsh, turn 4cncr (2cncr persons) BH ; ½Reel4 with 1cnrs, at end curve R to end as (3x,1x,2x)
- 25- All S&Link3 ; repeat (2,1,3)

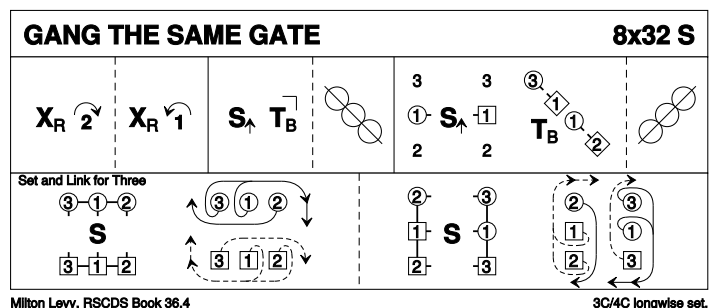

## 4 LINKS WITH ST PETERSBURG J32 · 3/4L

Malcolm Brown: RSCDS XLVI 10 · Crib: E-cribs · Diagram: Keith Rose's Diagrams

- 1- 1c+2c S&Link, finish 2c facing 1c NHJ ; S&Link to (2x,1x,3)
- 9- 1c, 2c following, dance down {3}, change sides with NHJ, W passing above M and under his arm, 2c+1c dance up to (2,1,3), 2c facing out
- 17- 2c turn 1c EH on sides ; 1c turn 3c EH, 1c finish BtoB facing 1cnr
- 25- SetH&G , petronella to (2,1,3)

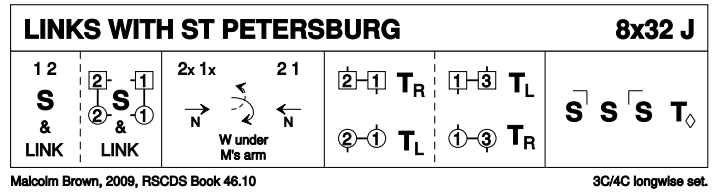

## 5 ELSPETH GRAY'S REEL R32 · 3/4L

Tom Toriyama: RSCDS LIII 7 · Crib: E-cribs · Diagram: Keith Rose's Diagrams

- 1- 1c cross RH to 2plx (2c up) | set to 1cnrs ; turn 1cnrs RH into facing lines3 across | all set
- 9- Reels3 across, 1c RSh to 1cnrs. 1c finish in 2plx (2,1x,3)
- 17- 1c dance to 2cnrs place **while{2}** 2cnrs turn RH  $\frac{3}{4}$  to 2plx and face out | 1M+3M & 1W+2W change places LH ; 1c dance to 1cnrs place **while{2}** 1cnrs turn LH  $\frac{3}{4}$  to 2plx and face out | 1M+2M & 1W+3W change places RH (3x,1x,2x)
- 25- All set | 2c+3c Link on sides to exchanged places **while{2}** 1c Petronella turn (Skip Ch) into facing lines3 across ; all set | 2c+3c Link across to exchanged places **while{2}** 1c Petronella turn (Skip Ch) to 2pl (2,1,3)

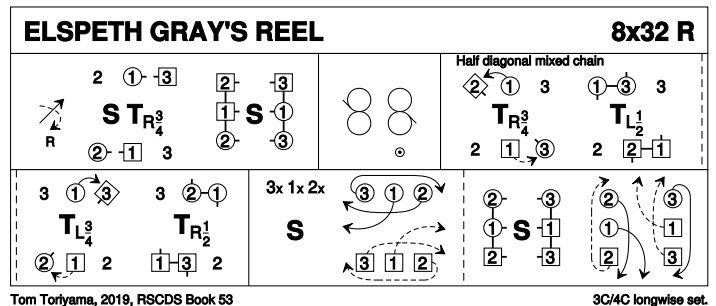

## 6 CULLA BAY S32 · 4S

Ann Dix: RSCDS XLI 2 · Crib: E-cribs · Diagram: Keith Rose's Diagrams

- 1- 1c+3c turn RH  $\frac{1}{2}$  with person opposite, face that person | twirl R and into opposite place ; 2c+4c repeat this and face in **while{4}** 1c+3c (W leading) chase  $\frac{1}{4}$  clw | curve into centre and swivel R to face out (1c facing 4pl and 3c facing 2pl)
- 9- Parallel Reels4 across
- 17- 2c+1c & 3c+4c circle4 L ; face other couple and set |  $\frac{1}{2}$  RHA, flowing into
- 25- 2c+4c LHA in the middle ; dance out passing same sex standing dancer on the side Rsh, and chase R (M leading) to 1pl/3pl (to 2,3,4,1).

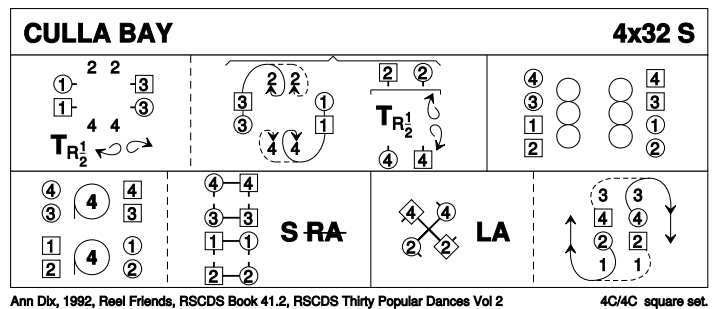

## 7 JENNIFER'S JIG J32 · 3/4L

John Drewry: RSCDS LIII 16 · Crib: E-cribs · Diagram: Keith Rose's Diagrams

- 1- 1c+2c+3c set | cross RH ; repeat & 2c face out
- 9- 1c+2c DblFig8 (1c cross down), at end 2c face out and up (1,2,3)
- 17- 1c+2c+3c Inveran reels (1c cross down, and cross up from the bottom, 2c+3c full reel3 on own side) (1,2,3)
- 25- 1c with 2c following lead down {3}, turn RH ½ {1} ; turn on ½ moving upwards | 2c+1c lead up (to 2,1,3)

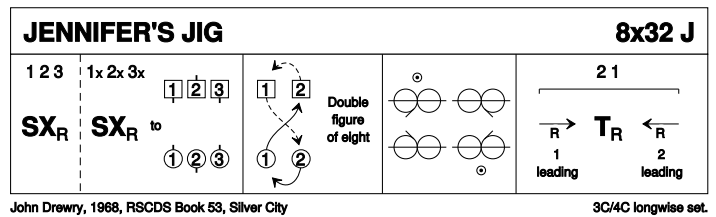

## 8 BROADFORD BAY R32 · 3/4L

Anne Grant: The Leaflet Dances with Music · Crib: E-cribs · Diagram: Keith Rose's Diagrams

- 1- 1c (leading)+2c (dance up to begin), dance between 3c, cast up and dance to top, and 1c cast off (to 2,1,3)
- 9- 2c+1c+3c G-Chain (2c cross to start), finish 2M & 1W facing out (2,1,3)
- 17- 2W+1M turn RH 1½ **while{4}** 2M+1W chase ½ round cclw ; 2W+1M chase ½ round clw to 1W/2M places **while{4}** 2M+1W turn LH 1¼ to face P on 2diagonal
- 25- 2c+1c diagonal Reel4 (to 2,1,3)

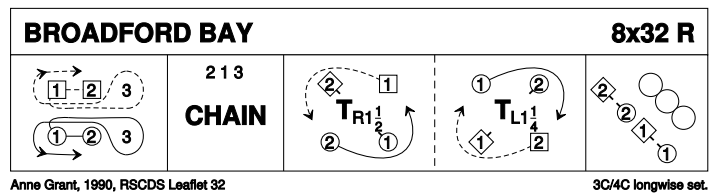

## Interval

## 9 UNCLE BILL'S JIG J32 · 2/4L

Roy Goldring: Graded and Social Dances 3 - 16 Dances · Crib: E-cribs · Diagram: Keith Rose's Diagrams

- 1- 1c+2c RHA ; 1c turn RH 1¼, finish 1W+2c in line across NHJ with 1M behind
- 9- All dance down the middle, on [12] 1c change place Rsh and 2c swivel inwards into ; 2c+1M in line across NHJ with 1W following dance up the middle, finish at top with 1W in 2pl on midline
- 17- 1M+1W cast R round 2W and cross to (2,1) ; 2c+1c Circle4 L
- 25- 2M+1W turn RH ; 2W+1M turn LH

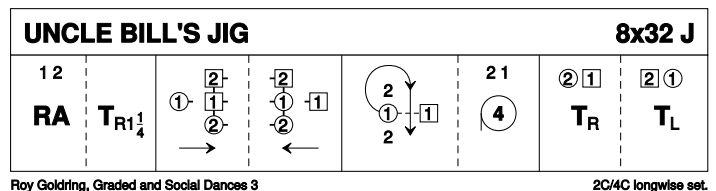

## 10 THE CLANSMAN R32 · 2/4L

Derek Haynes: RSCDS XXXII 8 · Crib: E-cribs · Diagram: Keith Rose's Diagrams

- 1- 1c cross RH | cast off (2c up) ; 2c+1c ½ RHA | set to P (1,2x)
- 9- 1c+2c R&L, finish with ¾ LH turn into line across, the W in the centre:
- 17- The Targe (1W+2W turn ¾ RH **while**{2} 1M+2M chase ¼ round cclw | 1M+2W & 1W+2M Turn LH ; repeat) finishing on sides (2,1x)
- 25- 2c facing 1c set | all set to P ; 1c lead up, cross and cast to 2pl (2,1)

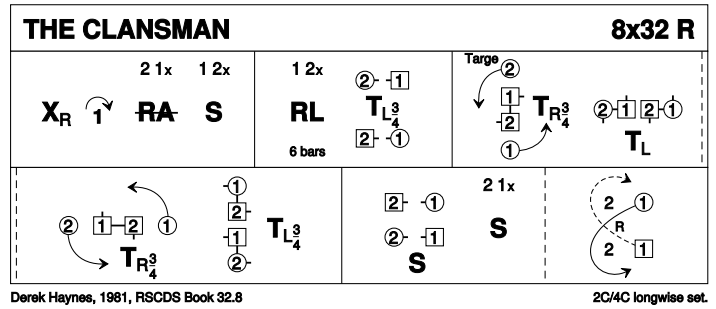

## 11 CAPE TOWN WEDDING S32 · 3/4L

Tom Kerr: RSCDS XXXIX 4 · Crib: E-cribs · Diagram: Keith Rose's Diagrams

- 1- 1c cross down (no hands) to 2plx (2c up) | change places with 3c EH ; 1c turn RH ½ | lead to top (2c+3c down) and face up in promhold
- 9- 1c with 2c Rsh Reel3 across, at the end 1c pivots inwards into 1pos on own side facing down NHJ, with 2c in 2pl, on [16] 3c step in and face up NHJ
- 17- All set, all Petronella (1c+3c in tandem) ; all set advancing {1} to join hands in circle, **while** setting {1} pull Rsh back tightly | and cast clw (to 1,2,3)
- 25- 1c+2c the Knot

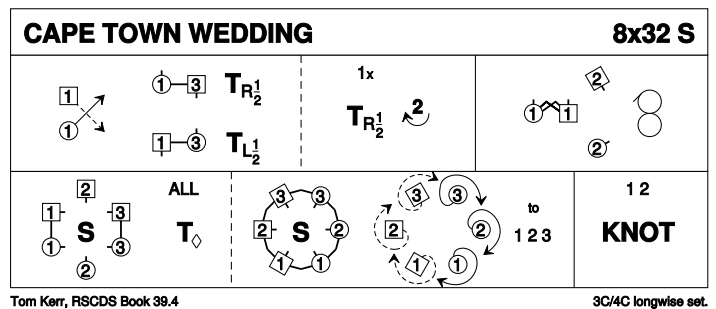

## 12 INCHMICKERY J32 · 5/5L

Roy Goldring: RSCDS LIII 23 · Crib: E-cribs · Diagram: Keith Rose's Diagrams

- 1- 1c+2c circle4 L ; 1c long cast to 3pl (2c+3c up) (2,3,1,4,5)
- 9- Teapots R ; and L (1c RHA with C on R ; LHA with C on L)
- 17- 1M+5W & 1W+2M Turn RH to places ; 1M+2W & 1W+5M repeat LH
- 25- 1c long cast to 5pl (4c+5c up) ; 5c+1c circle4 R (2,3,4,5,1)

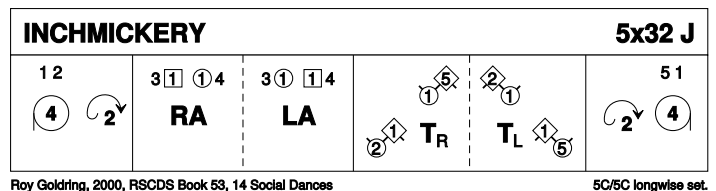

## 13 THE CELTIC CROSS R48 · 4S

Derek Haynes: *A Guide to Scottish Country Dancing (ex-Collins)* · Crib: E-cribs · Diagram: Keith Rose's Diagrams

- 1- All W RHA **while(4)** all M dance cclw half round ; W keep RHJ and give LH to new M, All set | all turn LH ½ to put M in middle
- 9- All M RHA **while(4)** all W dance cclw half round ; M keep RHJ and give LH to P, all set | turn LH ¼ to new places (3,4,1,2)
- 17- 1c+3c A&R ; ½ R&L to places
- 25- 2c+4c repeat
- 33- All set to P | turn RH to face cnrs ; set to and turn cnr RH to promhold, M inside
- 41- All Promenade cclw, M finish in own places, with the cnr as new P

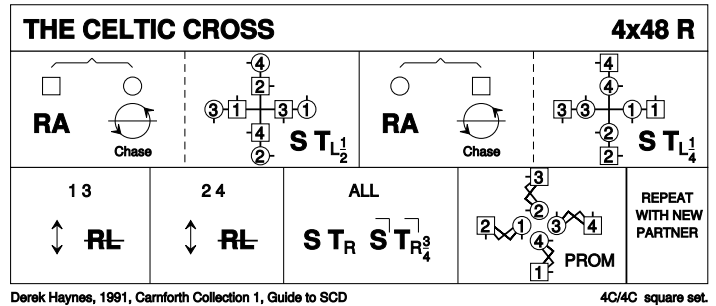

Repeat 3 times, each time with a new partner

## 14 THE MINISTER ON THE LOCH S32 · 3/3L

Roy Goldring: *Magazine Dances 2005-2009* · Crib: E-cribs · Diagram: Keith Rose's Diagrams

- 1- 1c+2c Pousette
- 9- 1c dance down 2 places, turn BH ; dance up 2 places, turn BH, open upwards and face out
- 17- 1c+3c DblFig8 round 2c, 1c casting, 3c crossing up to begin, 1c finish facing out for
- 25- 1W+2W & 1M+2M turn EH 1½ ; 1c+3c repeat (2,3,1)

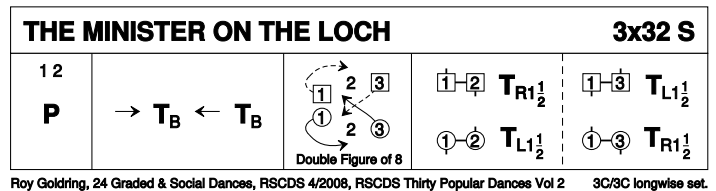

## 15 THE SHETLAND SHEPHERDESS J32 · 3/4L

Ron Wallace: *A Third Book of Graded Scottish Country Dances* · Crib: E-cribs · Diagram: Keith Rose's Diagrams

- 1- 1c dance between 2c and cast up to place ; dance ½ Fig8 round 2c (1x,2,3)
- 9- 1c cross down into mirror Reels3 on own side, 2c starting out and up (1,2,3)
- 17- 1c (start inwards) change place with 2c EH and face out | 1c turn 3c EH to face up in the middle ; 1c dance to top and cast off (2,1,3)
- 25- All A&R and clap on last beat of [28] ; All turn P RH (2,1,3)

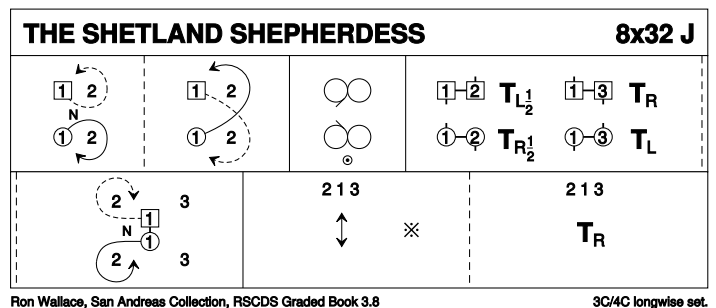

# 16 THE REEL OF THE ROYAL SCOTS

R32 · 3/4L

Roy Goldring: *The Leaflet Dances with Music* · Crib: *E-cribs* · Diagram: *Keith Rose's Diagrams*

- 1- 1W+2W (1M+2M) turn LH (RH) ½, finishing 1c BtoB in 2pl | All set as in DTr ; 1W+3W (1M+3M) turn RH (LH) ½ | 2c+3c+1c set as in DTr
- 9- 1c followed by 3c dance up between 2c, cast off ; dance NHJ down through 3pl, cast up to 2pl, 3c looping into 3pl (2,1,3)
- 17- 1c turn 1cnrs RH, pass RSh (cnrs dance for {4}) ; turn 2cnrs RH (same), and cross RSh to (2,1,3)
- 25- All circle6 and back (2,1,3)

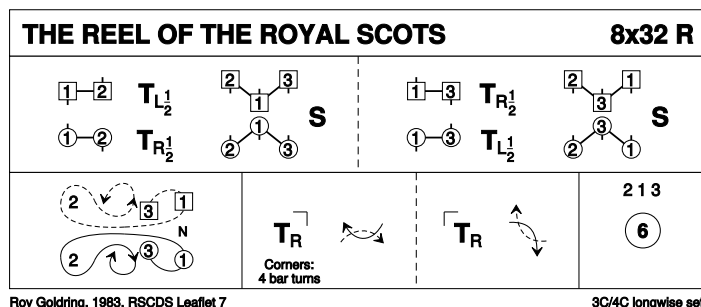

## Extras

### E1 [?] THE DURAN RANGER R32 · 3/4L

RSCDS XIII 1 · Crib: *E-cribs* · Diagram: *Keith Rose's Diagrams*

- 1- 1c lead down the middle (2c up on [3-4]), on [4] 1c change side while facing down, 1W passing below P under their joined R arms as 1c turn inwards ; 1c lead up on opposite side to (2,1x,3)
- 9- 2c+1c R&L, to face 1cnr
- 17- 1c turn corner, P, corner, P
- 25- 2c+1c circle4 and back (2,1,3)

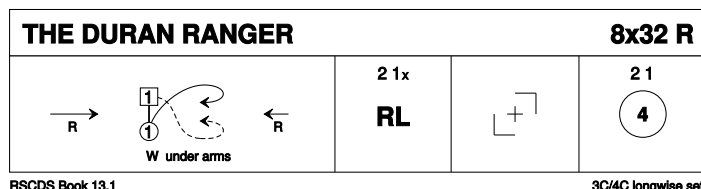

### E2 [?] BILL CLEMENT MBE J32 · 3/4L

John Wilkinson: *RSCDS XLVII 1* · Crib: *E-cribs* · Diagram: *Keith Rose's Diagrams*

- 1- 1c set | dance between 3c (2c up) and cast up to finish side by side LHJ facing 1cnr
- 9- Set to 1cnr and turn inwards and join RH | set to 3cnr ; turn 3cnr LH to face 2cnr RHJ
- 17- Set to 2cnr and turn inwards and join LH | set to 4cnr ; turn 4cnr RH to (2,1,3)
- 25- Circle6 and back

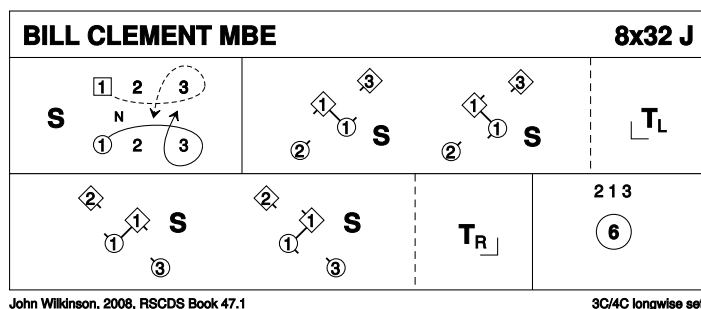

# E3 ? ROUGEMONT CASTLE S32 · 3/3L

Duncan Brown: RSCDS XLVIII 12 · Crib: E-cribs · Diagram: Keith Rose's Diagrams

- 1- 1c cross between 3c and cast up (2c up) ; ½Fig8 L (W up, M down) (2,1,3)
- 9- All cross RH | chase clw ¼ to lines across ; All cross up/dn RH | chase clw ¼ (3x,1x,2x)
- 17- Chain R&L (mid dancers change place RH with cnrs diagonally R | new mid dancers repeat LH with cnrs to L ; repeat to the R (2x,1x,3x) | 2c Cross RH **while(2)** 1c+3c turn RH ½ into
- 25- 1c+3c Allemande (2,3,1)

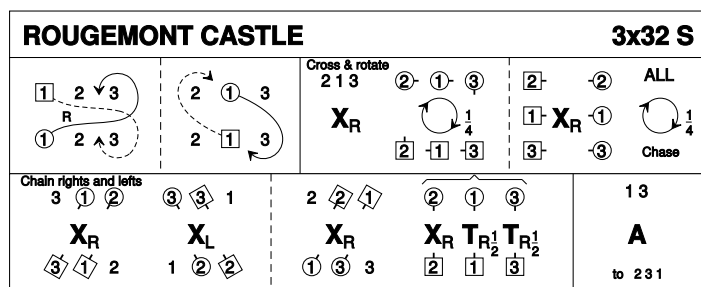

Duncan Brown, Exeter Branch 40, RSCDS Book 48.12

3C/3C longwise set.