

Leeds February Dance

15 February 2025

1 WELCOME TO AYR J32 · 3/4L

Jill Hendricksen/Kathy Stewart: RSCDS XLVII 8 · Crib: E-cribs · Diagram: Keith Rose's Diagrams

- 1- 1c+2c DbIFig8, 1c crossing down to start, at end 2c face out
- 9- 1c+2c turn EH 1¼ on side (2c to 1pl) and 1c face down NHJ; 1c dance down and turn 3c EH, 3c finish in 3pl and 1c facing 1cnr
- 17- 1c+1cnrs ½ diag. Reel4 and pass Rsh; repeat with 2cnrs, 1c finish on midline Lsh to Lsh facing own side
- 25- 3c+1M & 1W+2c RHA (3x,1x,2x); All chase clw ½ round (2,1,3)

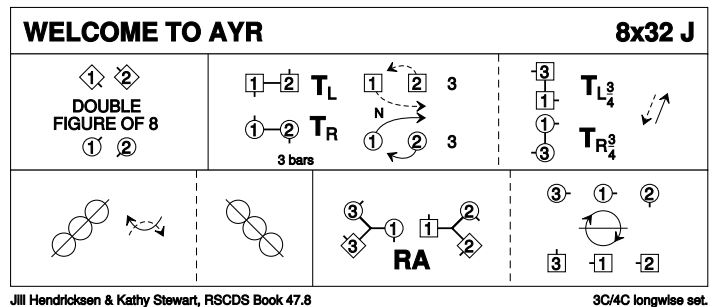

2 THE SAILOR R32 · 3/4L

RSCDS XXIV 4 · Crib: E-cribs · Diagram: Keith Rose's Diagrams

- 1- 1c cross down RH (2c up) to 2plx and BiL with cnrs; 1c cast R into lines across | all set
- 9- All Reels3 across, Rsh to 1cnr, finishing (2,1x,3)
- 17- 1c lead down | lead to the top; cross and cast to (2,1,3)
- 25- 2c+1c R&L.

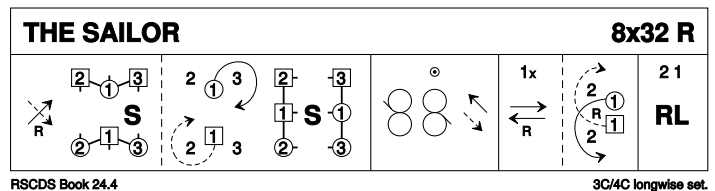

Note: [3-4] is NOT in DTr position.

3 BARBARA'S STRATHSPEY S32 · 3/4L

Sue McKinnell: RSCDS XLVI 4 · Crib: E-cribs · Diagram: Keith Rose's Diagrams

- 1- 1c set | cast (2c up); ½ Fig8 L (2,1x,3)
- 9- All set | 1c cross Rsh; 1c+3cnr turn RH 1½ (to 1,2,3 on M side, 2,3,1 on W side)
- 17- 3C Bourrel: 2W+3M chase cclw half round to midline while(4) 1M+3W & 2M+1W set adv | turn BH ¾ and pivot R, all facing P on midline (3,1,2); All set | All C turn BH ¾ to sidelines
- 25- All chase clw ½ round; all turn P RH ½ and twirl R to (2,1,3)

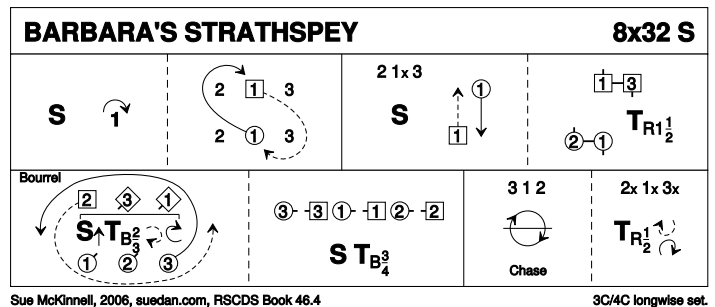

4 THE WAGGLE O' THE KILT J40 · 3/4L

James B Cosh: Twenty Two SCD · Crib: E-cribs · Diagram: Keith Rose's Diagrams

- 1- 1c cast off, lead through 3c (2c up), cast up, turn LH
- 9- 1M+2M+3M & 1W+2W+3W RHA (1c pass Rsh); 1W+2M+3M & 1M+2W+3W RHA (same hand!), 1c finish facing 1cnr
- 17- 1c ½Reel4 with 1cnrs, pass Lsh, ½Reel4 with 2cnrs and face 3cnr
- 25- 1c turn 3cnrs (1cnr person) RH ½, corners turn LH 1½ (or ½); 1c turn cnr RH ½, 1c turn LH to face 4cnr (2cnr person)
- 33- Repeat with 2cnr persons, 1c finish the LH turn (2,1,3).

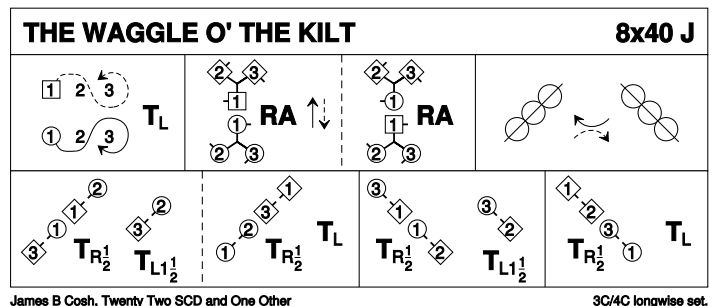

Note: on [13], the description says "change places", so 1c could also make a fast ½ LH turn into the other wheel)

5 LADY SUSAN STEWART'S REEL R32 · 3/4L

RSCDS V 9 · Crib: E-cribs · Diagram: Keith Rose's Diagrams

- 1- 1c set | cast off 2, meet below 3c ; dance to the top and cast off to face 1cnr (2c up)
- 9- SetH&G , at end 1c set advancing to face 1cnr
- 17- Turn CPCP, finish in the middle facing down NHJ on own side
- 25- 1c dance down | cast up round 3c ; dance up between 2c | cast off to (2,1,3)

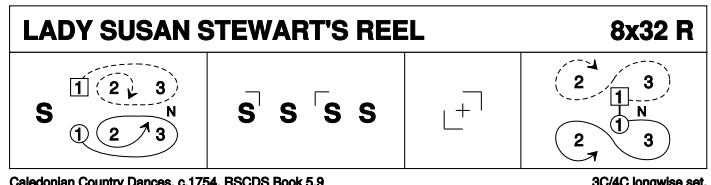

Caledonian Country Dances, c.1754, RSCDS Book 5.9

3C/4C longwise set.

6 THE GARRY STRATHSPEY S32 · 4/4L

James B Cosh: Twenty Two SCD · Crib: E-cribs · Diagram: Keith Rose's Diagrams

- 1- 1c+2c & 3c+4c ½R&L ; 1c+4c ½R&L (2x,4,1,3x)
- 9- 2c+4c & 1c+3c ½circle4 L | 2c+3c ½circle4 R ; 1c lead to top (others step down) (to 1x,4x,3x,2x)
- 17- End couples facing middle couples All Set H.Schottische ; half G-Chain (2,3,4,1)
- 25- All Reels4 on own sides.

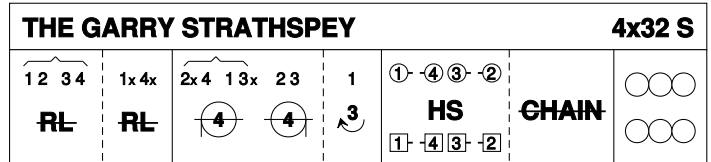

James Cosh, 22 SCD & One Other

4C/4C longwise set.

7 FATHER CONNELLY'S JIG J64 · 4/4L

John Drewry: The Donside Book · Crib: E-cribs · Diagram: Keith Rose's Diagrams

- 1- 1c+2c Set&Rotate (All set | cast one place clw ; change places RH with P | chase one place clw) (2,1,3,4)
- 9- ½ diagonal R&L with 1cnrs (W up, M down) while(4) the 2cnrs (2W+3M) set & cross RH, all cnrs face out ; ½ Reels3 on the sides, 1c Rsh to 2cnr pos. (no loops at the end) (2x,1x,3x,4)
- 17- Repeat figure from these positions with 2cnr persons (in 3cnr positions ; M up, W down) (to 2,1,3,4), 2c+3c finishing with loops into
- 25- Reels3 across (Lsh to 1cnr) (2,1,3,4)
- 33- 1c cross down RH between 3c | cast Rsh round new 1cnr (4W resp. 3M) ; change places up/dn LH | cast L (3c up) to (2,3,1,4)
- 41-56 3c+1c+4c repeat the figures [9-24] above (2,3,1,4)
- 57- 3c+1c+4c Circle6 and back (optional: 2c join in for Circle8 and back) (1c step down, to 2,3,4,1)

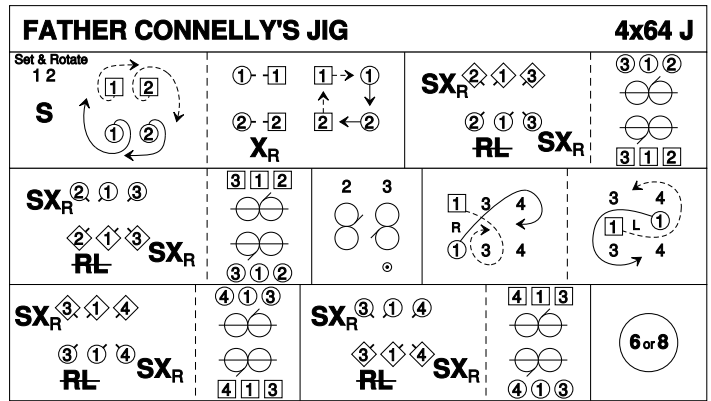

John Drewry, 1990, Donside Book

4C/4C longwise set.

(note by Drewry: This is really two successive 3c dances of 32 bars, the figures of bars 9-24 being similar.

8 THE REEL OF THE ROYAL SCOTS R32 · 3/4L

Roy Goldring: The Leaflet Dances with Music · Crib: E-cribs · Diagram: Keith Rose's Diagrams

- 1- 1W+2W (1M+2M) turn LH (RH) ½, finishing 1c BtoB in 2pl | All set as in DTr ; 1W+3W (1M+3M) turn RH (LH) ½ | 2c+3c+1c set as in DTr
- 9- 1c followed by 3c dance up between 2c, cast off ; dance NHJ down through 3pl, cast up to 2pl, 3c looping into 3pl (2,1,3)
- 17- 1c turn 1cnrs RH, pass RSh (cnrs dance for {4}) ; turn 2cnrs RH (same), and cross RSh to (2,1,3)
- 25- All circle6 and back (2,1,3)

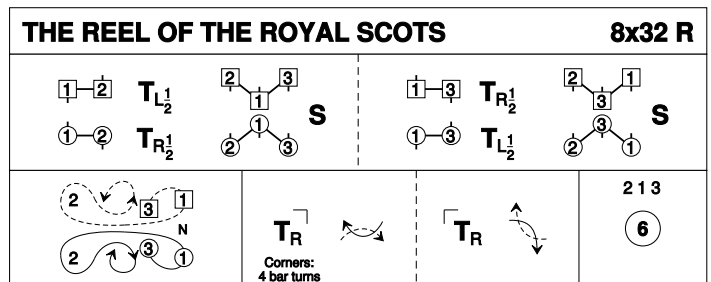

Roy Goldring, 1983, RSCDS Leaflet 7

3C/4C longwise set.

9 PROGRAMME ITEM – Interval

10 PELORUS JACK J32 · 3/4L

Barry Skelton: RSCDS XLI 1 · Crib: E-cribs · Diagram: Keith Rose's Diagrams

- 1- 1c cross RH, cast (2c up) ; 1c+3c RHA, finish 1M facing 1c, 1W behind him
- 9- 1c in tandem +1cns ½ diagonal Reel3, Rsh to 3W (1M & 1W loop R singly for lead change, so 1W now leads P) ; ½ diagonal Reel3, Rsh to 2W (+ lead change)
- 17- Continue pattern twice
- 25- 2c+1c LHA ; 1c turn LH ½ | all set (2,1,3)

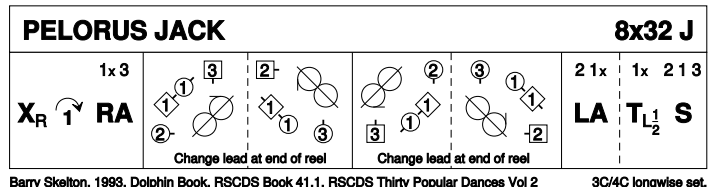

Barry Skelton, 1993, Dolphin Book, RSCDS Book 41.1, RSCDS Thirty Popular Dances Vol 2 3C/4C longwise set.

11 NONE SO PRETTY R40 · 3/4L

Thomas (19C) Wilson: RSCDS XIX 1 · Crib: E-cribs · Diagram: Keith Rose's Diagrams

- 1- 1c turn RH, cast off (2c up) ; turn 1¼ LH to finish 1W/1M between 2c/3c
- 9- Set twice in lines across, on [11-12] 1c petronella to opposite sidelines ; 2c+1c+3c set twice (2,1x,3)
- 17- Reels3 on sidelines (Rsh to 2cns), 1c finish BtoB between 2c facing opposite side (no loops at the end)
- 25- 1c+2c Reel4 across, at end 1c meet as 2c curves down into
- 33- 1c+2c Allemande (2,1,3)

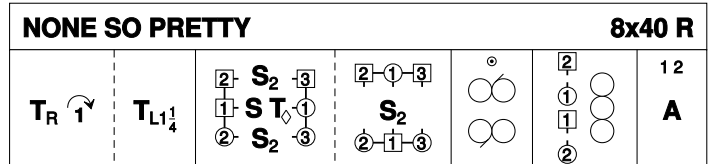

Wilson, 1816, RSCDS Book 19.1 3C/4C longwise set.

12 MISS MILLIGAN'S STRATHSPEY S32 · 3/4L

RSCDS: The Leaflet Dances with Music · Crib: E-cribs · Diagram: Keith Rose's Diagrams

- 1- 1c+2c circle4 L, finish NHJ 1c facing 2c ; set, 1c turning in to face up | 1c cast off, 2c dance up (2,1,3)
- 9- Mirror Reels3 on the sides, 1c start down and in, join hands when possible, 2c+3c finish with loops
- 17- 2c+1c+3c set | 2c+1c ½ LH turn and face down ; lead (LHJ) down, cross below 3c and cast up (1,2,3)
- 25- 1c+2c the Knot. (2,1,3)

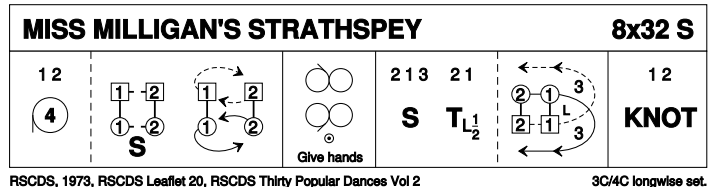

RSCDS, 1973, RSCDS Leaflet 20, RSCDS Thirty Popular Dances Vol 2 3C/4C longwise set.

13 THE NURSERYMAN J32 · 3/4L

Stephen Brown: RSCDS XXXVII 7 · Crib: E-cribs · Diagram: Keith Rose's Diagrams

- 1- 1c set | cross down RH (2c up) ; cast behind 3c, dance up NHJ to 2pl BtoB facing opp. side
- 9- 2c+1c+3c set as in DTr | All set advancing and swivel R to form "inverted" DTr (2c+3c are BtoB in centre) ; All set | All set advancing (1c into the middle) into
- 17- 2W+1M+3W & 2M+1W+3M RHA, 1c pass Rsh ; 1W+2W+3W & 1M+2M+3M LHA, finish in lines 1W between 2c facing 1M between 3c
- 25- Lines A&R ; 1c turn RH 1¼ to (2,1,3)

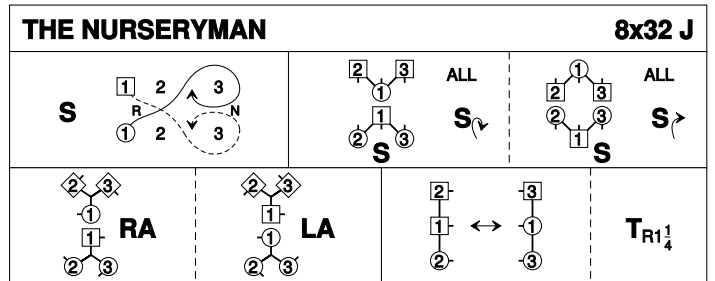

Steven Brown, 1988, RSCDS Book 37.7 3C/4C longwise set.

14 WEST'S HORNPIPE R32 · 4/4L

Five Traditional Scottish Country Dances for 1965 · Crib: E-cribs · Diagram: Keith Rose's Diagrams

- 1- 1c+2c+3c mirror Reels3 on opposite sides (1c cross down, 2c out and up)
- 9- Repeat, 1c now to own sides
- 17- 1c lead down ; and up to top to face 2c from the middle diagonally
- 25- 1c set to 2c | dance to the bottom (2c+3c+4c up) and turn inwards into ; 4c+1c Circle4 L (2,3,4,1)

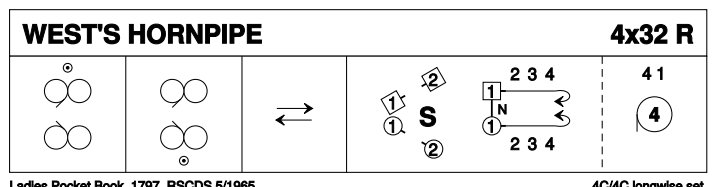

Ladies Pocket Book, 1797, RSCDS 5/1965 4C/4C longwise set.

15 THE ORCHARDS OF CO. ARMAGH S32 · 3/3L

Jinty Anderson: RSCDS LIII 14 · Crib: E-cribs · Diagram: Keith Rose's Diagrams

- 1- All chase clw ½ in a rectangular shape ; set | 3c & 1c turn RH ¾ into midline
- 9- ½ Reel4 on midline. On [12] 1M+3W pass LSh to face 2c across ; ½ Reel4 across. On [16] 1M+3W pass LSh to face P on midline
- 17- ½ Reel4 on midline ; 3c & 1c set | Petronella turn to sides (3,2,1)
- 25- 2c (+1c following) dance up to top | cast off (to 3,1,2) ; all turn P BH (3,1,2)

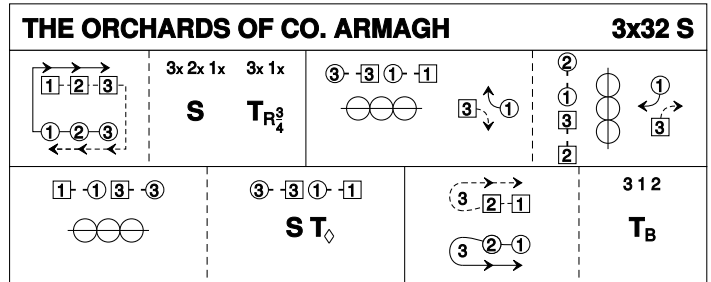

Jinty Anderson, RSCDS Book 53, Belfast Platinum Anniversary

3C/3C longwise set.

16 J. B. MILNE R32 · 3/4L

Hugh Foss: Thirty Popular Dances, Volume Two · Crib: E-cribs · Diagram: Keith Rose's Diagrams

- 1- 1M+2W set adv. | turn RH ; 1W+2M repeat (1,2,3)
- 9- 1c set advancing | turn BH and open upwards ; cast off one (2c up) | Petronella Turn to: facing lines across
- 17- 1c set | turn RH ¾ ; set | turn RH ¾ , **while(8)** 2c+3c pass RH on the sides | set ; cross RH | set
- 25- 1c set | pass RH ; cast R into 2pl, **while(6)** 2c+3c pass RH on the sides | set ; cross RH | all set. (2,1,3)

Notes: In [17-32] traditionally the corners set R to the person just passed, then L to the next person to pass.
In a variant for [19-24] 1c turns BH ¾ in PdB.

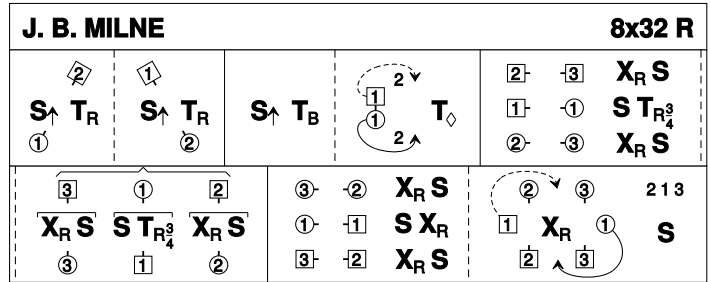

Hugh Foss, 1954, Angus Fitchet S D Album, RSCDS Thirty Popular Dances Vol 2

3C/4C longwise set.

17 GOOD HEARTED GLASGOW J32 · 3/4L

Peter Knapman: A Guide to Scottish Country Dancing (ex-Collins) · Crib: E-cribs · Diagram: Keith Rose's Diagrams

- 1- 1c turn RH | cast off (2c up) ; turn LH 1¼
- 9- Teapots R ; and L (2c+1W & 1M+3c RHA ; 2c+1M & 1W+3c LHA)
- 17- 1c lead down and up (2,1,3)
- 25- Circle6 and back

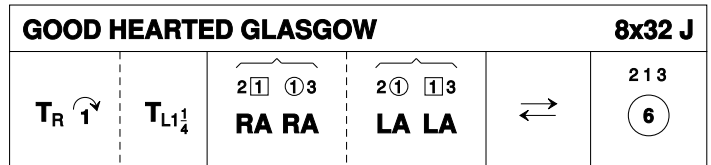

Peter Knapman, 1988, Collins Pocket Reference

3C/4C longwise set.

18 PROGRAMME ITEM – Extras

19 THE FRISKY J32 · 3/4L

Robert Bremner: RSCDS XXVI 10 · Crib: E-cribs · Diagram: Keith Rose's Diagrams

- 1- 1c turn RH | cast off (2c up) ; turn LH | cast off one (3c up) (2,3,1)
- 9- Circle6 and back
- 17- 1c lead to the top [**] (2c+3c down) ; 1c+2c set twice
- 25- 1c+2c ½ R&L ; 2c+1c set | cross RH (2,1,3)

[**] dance in {1}, dance up NHJ and out to 1pl {3}

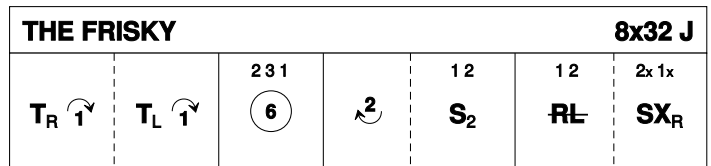

Thompson, 1774, RSCDS Book 26.10

3C/4C longwise set.

20 PEGGY DEWAR R32 · 3/4L

Joan Wright: RSCDS XXXVIII 1 · Crib: E-cribs · Diagram: Keith Rose's Diagrams

- 1- 1c set, cross down RH (2c up) ; behind 3c and dance up the middle to face 1cnr
- 9- 1c set to 1cnr, turn 1cnr RH to face 4cnr ; ½ Lsh Reels3 across, at the end 1c pass Rsh to face 3cnr pos. (2c+3c make loop)
- 17- 1c set to 3cnr pos. and turn cnr RH to face 2cnr pos. ; 1M+2c & 1W+3c ½ Lsh Reels3 across, 1c finish facing P up/down (2c+3c make loops)
- 25- 1c 1½ LH turn ; 1W+2c & 1M+3c RHA (2,1,3)

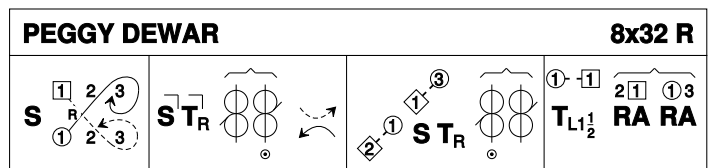

Joan Wright, RSCDS Book 38.1

3C/4C longwise set.

21 THE MORAY RANT S48 · 3/3L

John Drewry: Silver City Book of SCD · Crib: E-cribs · Diagram: Keith Rose's Diagrams

- 1- Inveran reels{6} (1c cross down from top, cross up from bottom) | 1c cross RH to (1x,2,3)
- 9- 1c set advancing | turn BH ; dance down between 2c, cast behind 3c, finish BtoB between 3c facing opp. side
- 17- 1M+3W & 1W+3M set & turn EH ¾ (1c start out between 2c and 3c) ; 1c dance up , cast up behind 2c, finish BtoB between 2c facing opp. side
- 25- 1M+2W & 1W+2M set & turn EH ¾ (1c start out between 2c and 3c) ; 1c ½Fig8 round 2c to (1,2,3) | 1c cast off **while{2}** 2c lead up (2,1,3)
- 33- 1c+2c Circle4 L ; 1c facing 2c NHJ set and 1c face up | 1c cast off **while{2}** 2c lead up (2,1,3)
- 41- 1c+3c repeat [33-40] to (2,3,1)

